



ELF2 Earth Leakage Relay

A00842

A00976

A01019

Manual Version 4.1

ELF2 Version 2.2

Operation Manual

ELF2 Manual

Part number:

A00842 500mA 500ms 110/240VAC, 24 – 48VDC

A00976 Multi-ranging 110/240VAC, 24 – 48VDC

A01019 Extended-range 110/240VAC, 24 – 48VDC

Manual Version 4.1

ELF2 Version 2.1

May 2008

Copyrights

All rights reserved. This document may not, in whole or part, be copied, photocopied, reproduced, translated, or reduced to any electronic medium or machine readable form without the express written permission of Bramco Electronics.

Disclaimer

Bramco Electronics has made every attempt to ensure that the information contained in this document is accurate and complete. Bramco Electronics makes no representation or warranties of merchantability or fitness for any particular purpose. Bramco Electronics reserves the right to make changes to the system and/or document at any time without notice.

Bramco Electronics

Unit 2&3 Callistemon Close,

Warabrook NSW 2304

Australia

www.bramco.com.au

Ph: +61 2 4014 4444

Fax: +61 2 4967 4100

Email: sales@bramco.com.au

Contents

1	OVERVIEW	4
1.1	Features	4
1.2	Physical Layout	5
1.3	Plug Connections on rear	7
1.4	Models	8
2	ELF2 OPERATION	9
2.1	Setup	9
2.2	Tripping	10
2.3	Resets	10
2.4	Output & Monitoring	11
2.5	Multi-Function DIP switches	12
3	SPECIFICATIONS FOR ELF 2	13
4	INSTALLATION	14
4.1	Mounting	14
4.2	Cabling	14
4.3	ELF 2 Operating voltage selection	15
4.4	EL Toroids	15
5	FAULT DIAGNOSIS	16
6	ELF 2 TYPICAL CONNECTIONS	17

1 OVERVIEW

The Bramco ELF 2 has been designed to detect Earth current faults flowing in a power system and to provide visual indication of Earth Leakage conditions.

This relay is specifically designed to protect systems supplying VF Drives and provides very high immunity to converter noise.

It is physically the same package as ELF relay, with the exception of the extra rear socket for RS485 connection, providing an easy upgrade path for the user.

1.1 Features

- High noise immunity for VSD loads
- Accurate and reliable current measurement and trip delays
- Easily configured latching/non-latching and failsafe/non-failsafe mode of operation
- Toroid open protection and indication
- LCD display provides:
 - Display of actual leakage current: as a direct mA value, as a bar graph and as a percentage of the trip point.
 - Readout of trip current and delay set points
 - Relay operational parameters
 - Last fault duration
 - Trip indication
- Adjustable trip current and delay time from front panel
- Front panel reset button, enabled via a link on the rear panel
- Provision for a remote reset button
- Status LEDs on the front panel for:
 - Power
 - Warning/fault
- Compatible with Bramco's standard Earth Leakage Toroid range – 500mA, 1A, 2A etc. (Note: for extended range detection beyond 500mA, matched toroid-relay pairs must be used)
- Current loop or voltage output 4-20mA or 2-10V output
- Clear hinged front cover offers protection to IP66 when properly mounted
- Multiple input voltage available as standard for relay
- Operates on limited and unlimited neutral systems.

1.2 Physical Layout

The ELF 2 relay enclosure is designed for through panel mounting with clamping kit supplied.

ELF2 Front View



ELF 2 Rear View

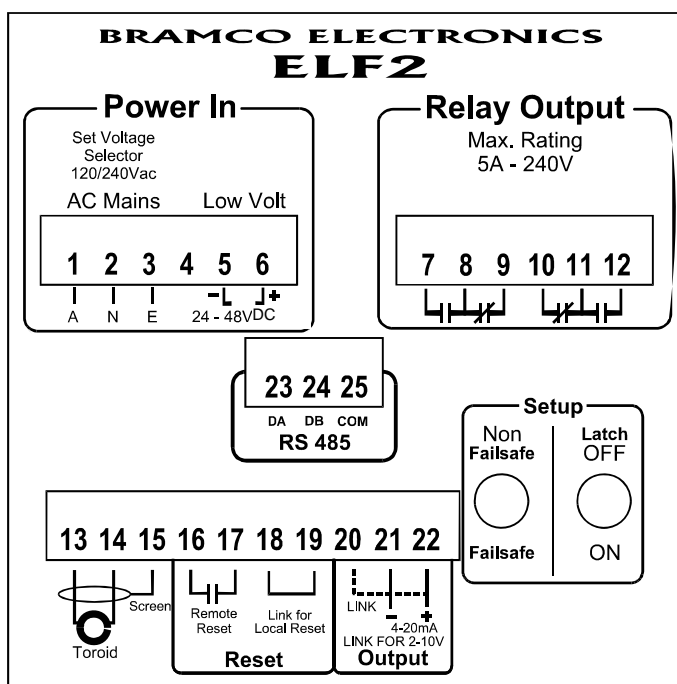

ELF 2 Basic Enclosure Dimensions

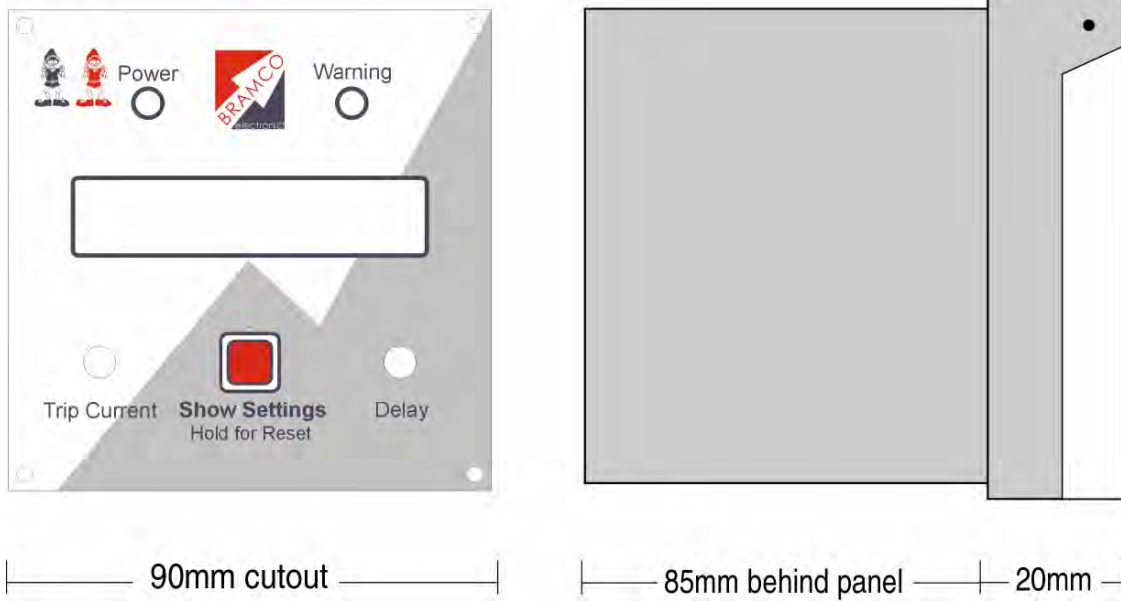

NOTE: Allow 50 mm minimum rear depth behind ELF 2 to allow for cabling to Pheonix plugs.

ELF 2 Mounting Panel cut-out dimensions

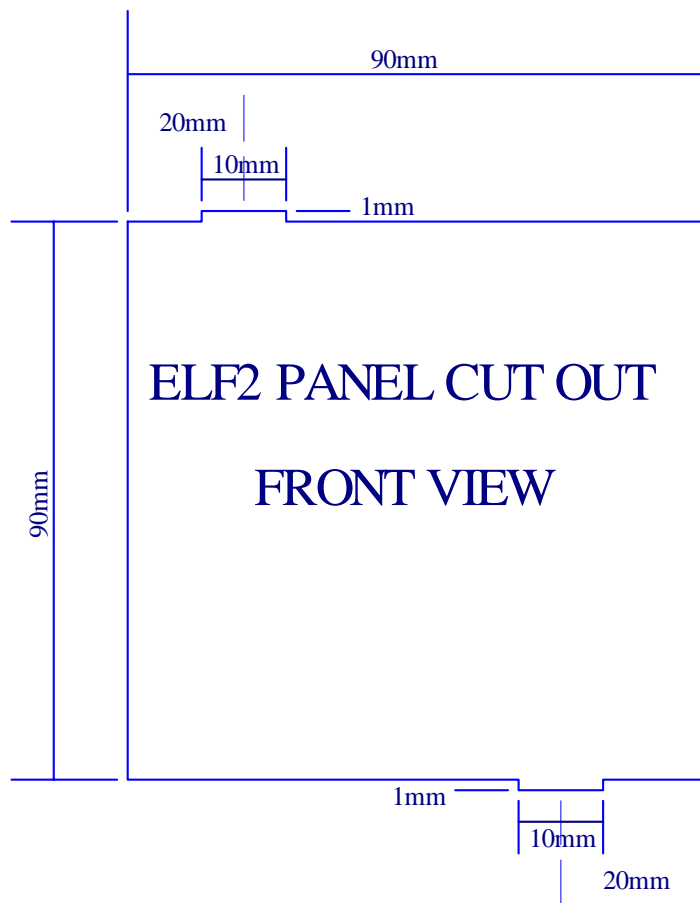

1.3 Plug Connections on rear

Terminal Number	Terminal Function
1	AC power
2	AC power
3	EARTH
4	Spare No Connection
5	DC NEG (ISOLATED)
6	DC POS (ISOLATED)

Terminal Number	Terminal Function
7	EL N/O
8	EL COM
9	EL N/C
10	EL N/C
11	EL COM
12	EL N/O

Optional RS485 Port

Terminal Number	Terminal Function
23	RS485 DA
24	RS485 DB
25	RS485 0V

Terminal Number	Terminal Function
13	EL TOROID
14	EL TOROID
15	SCREEN EL TOROID
16	REMOTE RESET
17	REMOTE RESET
18	ENABLE LOCAL RESET
19	ENABLE LOCAL RESET
20	VOLTS POS OUTPUT (Link to 22)
21	mA/V Neg OUTPUT
22	4 – 20mA Pos OUTPUT

1.4 Models

Three models of the ELF2 are available:

A00842

Implements the full functionality of the ELF2, with the exception of limiting the trip parameters to a maximum of 500mA and 500ms. This is in compliance with AS2081:2002.

A00976

Implements the full feature set described above, and provides the following options for trip ranges:

- Current ranges – 500mA, 1A, 2A and 5A ranges. Trip point may be set between 10% and full-scale.
- Time ranges – 500ms, 1s, 2s and 5s ranges. Trip delay time may be set between 30ms and full-range.

A01019

Implements the full ELF2 feature set, and provides the following options for trip ranges:

- Current ranges – 2A, 5A, 10A and 20A ranges. Trip point may be set between 10% and full-scale.
- Time ranges – 2s, 5s, 10s and 20s ranges. Trip delay time may be set between 30ms and full-range.

2 ELF2 OPERATION

The ELF2 monitors the amount of current passing through an Earth Leakage Toroid. If the measured current exceeds the trip current for the nominated fault time, the relay will trip, changing the state of its trip contacts (terminals 7-12) and indicating a fault on the LCD.

The trip ranges are as follows:

- 50mA to 500mA and 30ms to 500ms for the 500mA/500ms only ELF2 A00842 (AS2081:2002 compliance)
- 10% of full-scale current to full-scale (e.g. 100mA to 1A) and 30ms to full-range (e.g. 2s) for the multi-range ELF2 A00976 and extended range ELF2 A01019.

PLEASE NOTE: for the multi-range and extended-range ELF2 products, the relay will be supplied with a matched toroid. It is important that the relay and its matching Earth Leakage Toroid are used in conjunction with one another, for accuracy and reliability.

2.1 Setup

The parameters that may be adjusted to set up the ELF2 are the following:

- **Trip Delay Time:**
Adjusted using the *Delay* knob on the front panel of the relay.
A cascaded timing scheme (covering all EL protection equipment) is recommended.
- **Trip Current:**
Adjusted using the *Trip Current* knob on the front panel of the ELF2.
- **Failsafe/Non-Failsafe:**
Set using the selector switch on the rear panel.
In failsafe mode, the trip contacts energise when the relay is healthy – e.g. a N/C contact will be *open* when the relay is healthy.
In non-failsafe mode, the trip contacts energise when the relay is unhealthy – e.g. a N/C contact will be *closed* when the relay is healthy.
- **Latching/Non-Latching:**
Set using the selector switch on the rear panel.
In the latching mode, the trip contacts remain in the *tripped* position until the fault clears AND a reset (either local or remote) is initiated by the user.

2.2 Tripping

The conditions for a trip are:

- EL current exceeding the trip current passes through the detection toroid for a period greater than the delay time specified.
- The toroid is disconnected from the relay.

If a trip condition is detected, the trip contacts change state. In failsafe mode, the contacts will de-energise under a trip condition. In non-failsafe, the contacts energise with a trip.

Note: the commit time for a trip is 25ms less than the delay time. That is, if a fault condition persists for *longer* than 25ms less than the trip delay, but *shorter* than the trip delay itself, the unit will still trip. This is a deliberate behaviour, to adjust for the internal hardware pickup time for handling the trip.

2.3 Resets

To reset the ELF2, the fault (earth leakage or no toroid) must firstly be cleared. If the trip condition was an EL fault, the measured earth leakage current must fall below 80% of the trip current set point.

In **non-latching** mode, the ELF2 will reset automatically once the fault is gone. In **latching** mode, the user must reset the ELF2 manually by either using a local or remote reset.

Local Reset must be enabled by linking terminals 18 and 19. The reset button must be pushed, held for 2 seconds and released to reset the unit.

Remote Reset can be enabled by wiring a N/O pushbutton to terminals 16 and 17. The button must change state from open to closed to carry out the reset.

2.4 Output & Monitoring

There are 3 output types:

- **LED indication**

A *steady green* LED indicates that the unit is powered.

A *flashing red* LED indicates that the EL fault level is between 80% and 100% of the trip point

A *steady red* LED indicates EL fault level > 100% trip point or toroid fault

- **4-20mA / 2-10V terminals**

A scaled indication of the percentage of full scale: 4mA/2V indicates no EL fault current, 20mA/10V indicates EL fault level \geq full scale.

4-20mA: Terminal 21 positive, terminal 22 negative. Maximum loading 250 Ω .

2-10V: Terminals 20 & 22 linked. Terminal 21 negative, terminal 22 positive.

Note: the output is scaled against the full scale of the unit (500mA, 1A etc) rather than the set point.

- **LCD**

Four main functions:

- **Main Screen:** shows trip settings and fault level
- **Settings Screen:** shows trip settings (time, current), plus operational mode (failsafe/non, latching/non). Accessed via button press.
- **Fault Indication:** shows fault type when relay is tripped or latched
- **Fault Duration:** shows last EL fault duration. Accessed by holding button.

2.5 Multi-Function DIP switches

This is a non user setting. The switches allow various time and current ranges to be set. These switches should only be changed after consultation with a Bramco Technical Representative.

Note that the 500mA/500ms-only version of the ELF2 (A00842) is unaffected by the DIP settings, in accordance with AS2081:2002.

If a different current range is required, changing the DIP settings is insufficient to complete the change. The relay and toroid must both be sent to Bramco for adjustments and recalibration. For extended range ELF2s (1A or greater), a matched toroid is required for accuracy and reliability.

On each of the time range settings, the minimum set point is 30ms.

A00976 Multi-range ELF2:

DIP Numbers		Current Range	DIP Numbers		Time Range
1	2		3	4	
OFF	OFF	500mA	OFF	OFF	500ms
OFF	ON	1A	OFF	ON	1s
ON	OFF	2A	ON	OFF	2s
ON	ON	5A	ON	ON	5s

A01019 Extended-range ELF2:

DIP Numbers		Current Range	DIP Numbers		Time Range
1	2		3	4	
OFF	OFF	2A	OFF	OFF	2s
OFF	ON	5A	OFF	ON	5s
ON	OFF	10A	ON	OFF	10s
ON	ON	20A	ON	ON	20s

3 SPECIFICATIONS FOR ELF 2

Supply Voltage	<p>120V or 240V Selectable $\pm 20\%$ 50/60Hz, 2VA, Terminals 1, 2 & 3. <i>NOTE: ELF 2 when shipped is set to 240vAC</i></p> <p>24 – 48VDC $\pm 20\%$, 2VA, Terminals 5 & 6. <i>NOTE: This DC supply must be isolated from Earth</i></p> <p>Supply Voltage select switch is accessed through a hole in the top of the enclosure. Use screw driver to alter setting.</p>
Trip Current Range	<p>A00842: 50 – 500mA AC</p> <p>A00976: 10% - full-scale for 500mA, 1A, 2A or 5A AC selectable.</p> <p>A01019: 10% - full-scale for 2A, 5A, 10A or 20A AC selectable.</p>
Frequency Range	20 – 200Hz Sinusoidal
Trip Delay Range	<p>A00842: 30 – 500ms</p> <p>A00976: 30ms – full-range for 500ms, 1s, 2s, 5s selectable</p> <p>A01019: 30ms – full-range for 2s, 5s, 10s, 20s selectable</p>
Earth Leakage Current Monitor	<p>4 – 20mA into 250 ohms maximum. Terminals 21 & 22 2 – 10v available by linking terminal 22 to 20. <i>NOTE: Do NOT Earth Pos or Neg.</i></p>
Relay Function	<p>Failsafe or Non-Failsafe (Switch selection) Latching or Non-Latching (Switch selection)</p>
Latch Reset	<p>Local Reset: Enabled by linking terminals 18 & 19 Push and hold for 2 seconds for reset</p> <p>Remote Reset: Momentary closure of terminals 16 & 17 from remote N/O pushbutton for reset</p>
ELF 2 Contact ratings	<p>2 x C/O 5A 250vAC, 100vA max 5A 30vDC Resistive 3A 30vDC Inductive load 90W L/R 7mS</p>
Maximum Switching Voltage	380vAC/125vDC

4 INSTALLATION

4.1 Mounting

The ELF 2 relay is fascia packaged for through-panel mounting. Panel cut out is 90 x 90 mm. See the "Physical Layout" section for cut-out detail.

Use sealing gasket provided, positioned behind front bezel for panel sealing, and use the 2 adjustable clamps to fasten ELF 2 to mounting panel. When mounted as above the exposed ELF 2 Relay bezel has IP66 rating.

ELF 2 relay and EL Toroid should be mounted away from stray flux sources such as power supplies, transformers, control relays and contactors and cables carrying load currents.

4.2 Cabling

Use 2 core screened cable for the following inputs:

- EL Toroid
- EL Remote LATCH RESET (voltage free contact).

Each individual cable screen should be connected to the ELF 2 relay to Terminal 15.

NOTE: Do not earth the non-relay end of these screened cables.

It is recommended that these 2 screened cables are run by a direct route to the ELF 2 relay, BUT are not to run with, or in cable harness or ducting with control or power cabling.

Where necessary, cross other cables at 90 degrees and provide maximum clearance from high voltage/current circuits as much as practically possible.

4.3 ELF 2 Operating voltage selection

Two options are available for powering the ELF2 – AC or LV DC

AC Power:

Either 120vAC or 240vAC input is connected to Terminals 1 and 2.

Before powering the ELF 2, check and adjust to the matching voltage setting on the internal voltage selector switch. The switch is accessed through the top of the relay ELF 2 body.

The factory setting is 240v.

NOTE: If powered from 240vAC with the 120v switch setting, the ELF2 will be damaged.

Low voltage DC Power:

For 24 – 48VDC, input is connected to terminals 5 (Neg) and 6 (Pos). This must be an isolated power supply source.

NOTE: For correct operation of the ELF2, this supply must not be earthed.

4.4 EL Toroids

IMPORTANT: Match the EL Toroid Scaling with ELF 2 relay.

For the A00842, a standard 500mA Bramco EL toroid should be used.

For the A00976 and A01019, a current-matched and calibrated toroid pair should be used.

EL toroids have a powder coated mild steel, open faced enclosure, which acts as a shield to stray flux. For this to be effective the open side of the ELT should face away from stray flux sources such as transformers, relays and contactors, and for best effect, facing but not touching the steel enclosure body.

The three phase load power cables should be arranged to pass symmetrically through the centre of the EL toroid window. If the cables are asymmetrical through the centre of the toroid, incorrect EL detection may occur.

5 FAULT DIAGNOSIS

To assist in fault diagnosis, a variety of typical faults are shown, with possible solutions given

Indication	Possible Condition/Suggestion
LED Indication	
Power LED is OFF	Power supply is incorrectly connected or switched off. Check either 110/240VAC or 24-48VAC/DC is connected.
Power LED is ON	Relay is operational. Control relay output state is dependent on failsafe/non-failsafe and the presence of any fault conditions
Warning LED is OFF	Earth leakage current below 80% AND toroid connected properly
Warning LED FLASHING	Earth leakage current above 80% but beneath 100% of trip point
Warning LED SOLID	Earth leakage current above 100% OR toroid fault
LCD - Information Screens	
CCCmA EEEEEEEEEEE AAAmA DD% BBBmA	<i>Status Screen</i> A: Fault current set point, mA or A B: Trip delay set point, ms or s C: Measured earth leakage current, mA or A D: Measured earth leakage as a percentage of set point E: Bar graph representation of percentage earth leakage Constantly viewable if no button pressed or fault condition present
LATCHING FS AAAmA BBBmA	<i>Summary Screen</i> A: Fault current set point, mA or A B: Trip delay set point, ms or s Shows operational mode: latching/non-latching, failsafe/non-failsafe Accessed by momentary press of local reset. Remains for 5 seconds.
FAULT DURATION: AAAmS	<i>Fault Duration Screen</i> A: Time in ms or s of last fault detected by ELF2 Accessed by pressing local reset for 2 seconds. Remains for 5 seconds.
LOCAL RESET DISABLED	<i>Local Reset Lockout Screen</i> Local reset is not enabled; link terminals 18 & 19 to enable.
HOLD BUTTON TO RESET RELEASE BUTTON TO RESET	<i>Local Reset Screens</i> Viewable by initiating a local reset when a latched fault has occurred and the fault condition has cleared
LCD - Fault Messages	
EL FAULT TRIPPED LATCHED	Earth leakage current has exceeded trip current and time settings. Latch has been set. Fault must clear and manual latch reset to become healthy.
TOROID FAULT TRIPPED LATCHED	Open toroid - check toroid connections. Fault must clear and manual latch reset for relay to become healthy.
EL FAULT TRIPPED NO LATCH	Earth leakage current has exceeded trip current and time settings. Relay will become healthy when fault clears.
TOROID FAULT TRIPPED NO LATCH	Open toroid - check toroid connections. Relay will become healthy when fault clears.
RELAY TRIPPED TRIPPED LATCHED	Latch from a previous fault exists, fault type unable to be determined. Usually when latched at startup. Requires latch reset for healthy relay.

6 ELF 2 TYPICAL CONNECTIONS

